

MDTA Series

FEATURES

-
-
-
-
-
-
-

APPLICATION

-
-

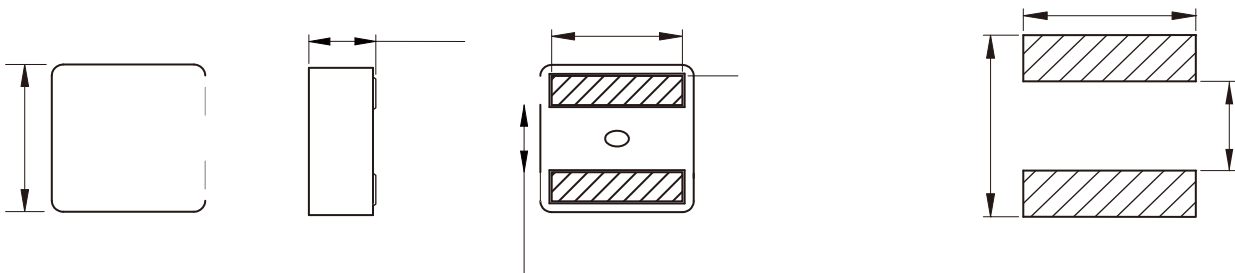

Part No	L@100KHz /0.1V	Tolerance	I _{SAT} Typ.	I _R		R _{DC} Max.	D
				20°C rise	40°C rise		

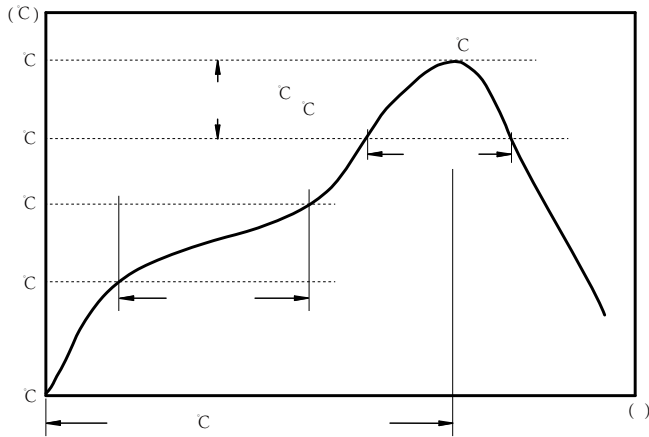

c
c
c

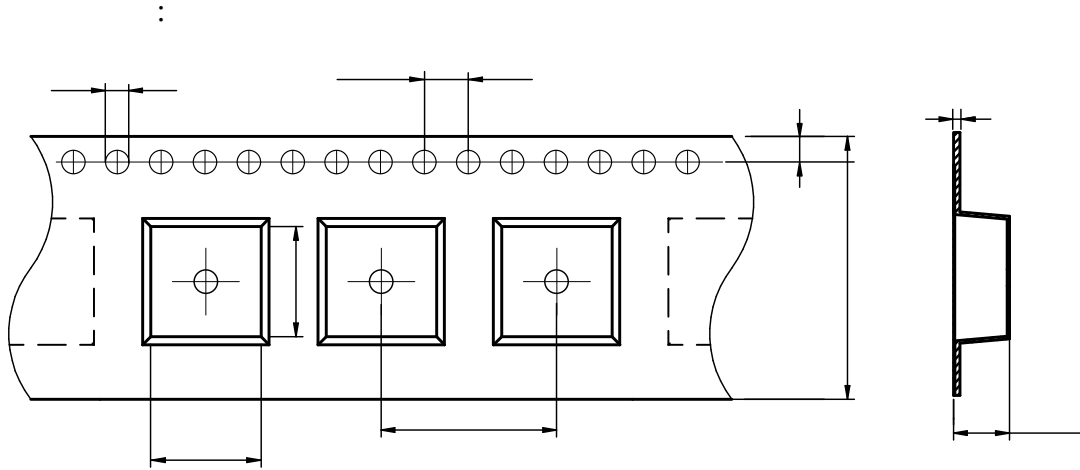

MDTA8080	9.4± 0.1	8.9± 0.1	1.5± 0.1	4.0± 0.1	16.0± 0.1	24.0± 0.3	8.5± 0.1	1.75± 0.1	0.50± 0.05
----------	----------	----------	----------	----------	-----------	-----------	----------	-----------	------------

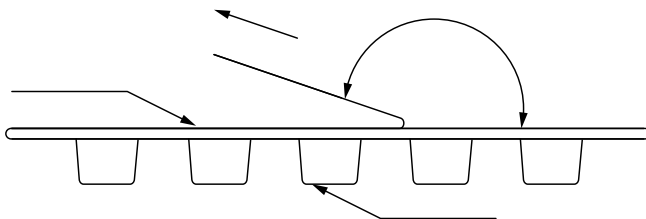

The peel force of top cover tape shall be between 0.1 to 1.3 N

Marking	Printing Inductance)
---------	----------------------

